

DIMENSIONS & PIPE CONNECTIONS						
"A"	NO.	NAME	PORT SIZE	QTY	MATERIAL	STYLE
30" - 80.55"	N1	INLET	8"	1	316L	FLANGE
40" - 90.55"	N2	OUTLET	8"	1	316L	FLANGE
-	N3	GAUGE PORT	0.5"	1	316L	NPTF
-	N4	VENT PORT	0.5"	1	316L	NPTF
-	N5	DRAIN PORTS	1"	2	316L	NPTF

HOUSING SPECIFICATIONS	
DESIGNED PRESSURE (PSIG)	195
OPERATING PRESSURE (PSIG)	150
OPERATING TEMP (°C)	110

- TECHNICAL PARAMETERS**
1. THIS APPARATUS MEETS GMP STANDARD
  2. ALL WELD-SEAMS ARE ARGON WELDED
  3. MAXIMUM CORROSION RESISTANCE
  4. SURFACE FINISH: 320# MACHINE POLISH-PASSIVATE.
  5. MATERIAL: 316L

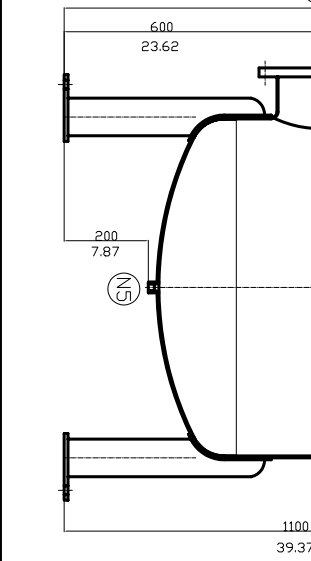

UNLESS OTHERWISE SPECIFIED	MATERIALS	ITEM	QTY	LIST OF MATERIAL	NUMBER
All dimensions are in inches. Remove all burrs and break sharp edges. Tolerances: Decimals: <b>.XX ± .01</b> <b>.XXX ± .005</b> Angles ± 1° Surface Roughness $\sqrt{32}$ DO NOT SCALE PRINT	SURFACE TREATMENT	ACAD FILE #	TD80R.DWGC		
		DWN BY	DATE		
		CHK BY	DATE		
		APPD BY	DATE		
		APPD BY	DATE		
		APPD BY	DATE		
		RELEASE	DATE		
		SIZE	DWG NO	TD80R	REV
					-

CRITICAL PROCESS FILTRATION, INC  
 NASHUA, NH  
 WWW.CRITICALPROCESS.COM  
 PH: 603-880-4420

CH SERIES - SALES DRAWING  
 80 ROUND  
 INDUSTRIAL SWING BOLT