

# SPS Mini-Capsule Filters

Single Layer Asymmetric PES Membrane



Validated for use in multiple pharmaceutical applications

Excellent flow rates with high throughput

Integrity testable

Designed for minimal leachables and extractables

Low adsorption of proteins and preservatives

## SPS Mini-Capsule Filters - Dimensions

Diameter	Length	Filtration Area
75 mm (2.95")	Body Length = 2.85" (72.4mm) Overall Length = 3.75" to 5.19" (Varies with Choice of Inlet/Outlet)	500 cm <sup>2</sup> (0.5 ft <sup>2</sup> ) (nominal)

## Flow Rates

The following table represents typical water flow at a one psi (69 mbar) pressure differential through a mini-capsule filter with 1/4" hose barb inlet and outlet ports. The test fluid is water at ambient temperature. Higher pressure drops are acceptable, but as flows increase the pressure drop of the housing becomes more apparent.

Pore Size	0.03 µm	0.10 µm	0.22 µm	0.45 µm	0.65 µm	0.80 µm	1.0 µm	1.2 µm
<b>GPM</b>	.05	0.11	0.21	0.42	0.53	0.87	0.98	1.00
<b>LPM</b>	0.2	0.4	0.8	1.6	2.0	3.3	3.7	3.8

## Construction Materials

<b>Housing</b>	Polypropylene
<b>Filtration Media</b>	Single Layer Asymmetric Polyethersulfone (PES) Membrane
<b>Media Support</b>	Polypropylene
<b>End Caps</b>	Polypropylene
<b>Center Core</b>	Polypropylene
<b>Outer Support Cage</b>	Polypropylene
<b>Sealing Method</b>	Thermal Bonding

## Applications

- ◆ Diagnostics
- ◆ Vaccines
- ◆ LVPs and SVPs
- ◆ Biologicals
- ◆ WFI Water
- ◆ Ophthalmics

SPS Mini-Capsules are hydrophilic and manufactured with the highest quality asymmetric polyethersulfone membrane. Polyethersulfone (PES) membrane exhibits excellent flow rates with high throughput. SPS capsule elements are 100% integrity tested during production.

Laboratory and pilot scale applications for SPS mini-capsule filters are final, sterilizing filtration of USP Water for Injection (WFI), diagnostic solutions, vaccines, ophthalmics, SVPs, LVPs and biological products.

Polyethersulfone is particularly suited for the filtration of products containing elements that can adsorb to media, such as preservatives and proteins. The lower binding characteristics of polyethersulfone (PES) make it a good choice for of protein solutions such as vaccines, biopharmaceuticals and ophthalmics.

## Sanitization/Sterilization

**Autoclave** ..... 250° F (121° C), 30 min, 5+ cycles

**Chemical Sanitization** ..... Industry standard concentrations of hydrogen peroxide, peracetic acid, sodium hypochlorite and other selected chemicals.

**Note** ..... SPS mini-capsules are not suitable for inline steam sterilization.

**Pre-Sterilized** .... SPS mini-capsules are offered in both non- and pre-sterilized forms.

## Maximum Operating Parameters

<b>Liquid Operational Pressure</b>	80 psi (5.5 bar) at 20 °C (68 °F)
<b>Gases Operational Pressure</b>	60 psi (4.1 bar) at 20 °C (68 °F)
<b>Operating Temperature</b>	43 °C (110 °F) at 30 psi (2.1 bar) in water
<b>Forward Differential Pressure</b>	50 psid (3.4 bard) at 20 °C (68 °F)
<b>Reverse Differential Pressure</b>	40 psid (2.7 bard) at 20 °C (68 °F)
<b>Recommended Changeout Pressure</b>	35 psid (2.4 bard)

## Integrity Test Specifications - Bubble Point

Pore Size	Bubble Point (water wetted membrane)
0.03 µm	**
0.10 µm	**
0.22 µm	50 psig (3.5 barg)
0.45 µm	25 psig (1.7 barg)
0.65 µm	19 psig (1.3 barg)
0.8 µm	15 psig (1.1 barg)
1.0 µm	10 psig (0.7 barg)
1.2 µm	8 psig (0.6 barg)

\*\* Test pressure exceeds operational limits of capsule filters. Use the diffusion test method.

## Validation

SPS filters are validated using test procedures that comply with the intent of both ASTM F 838-05 and HIMA protocols for the determination of bacterial retention in filters used for liquid filtration. The filters are validated to remove 10<sup>7</sup> organisms per cm<sup>2</sup> of filter media:

0.10 µm challenged with *Acholeplasma laidlawii*;  
 0.22 µm challenged with *Brevundimonas diminuta*;  
 0.45 µm challenged with *Serratia marcescens*;  
 0.65 µm challenged with *Saccharomyces cerevisiae*.

Critical Process Filtration can provide validation assistance.

## We Do It Right the First Time

We solve filtration challenges where filters are a critical part of your manufacturing process. Our Technical Team works with you to engineer filtration solutions that fit your needs. Then we manufacture the filters in our ISO 9001 certified facility and deliver them fast, so you have the right filters when you need them.

## Ordering Information

Mini-Capsule order number example: Pharmaceutical Grade, Single Layer, Asymmetric Polyethersulfone (PES) Membrane, 0.22 Micron Rating, Non-Sterile, 1/2" Sanitary Inlet, Luer Lock Inlet Vent, 1/2" Sanitary Outlet, Luer Lock Outlet Vent = MCSPS-20N0005454.

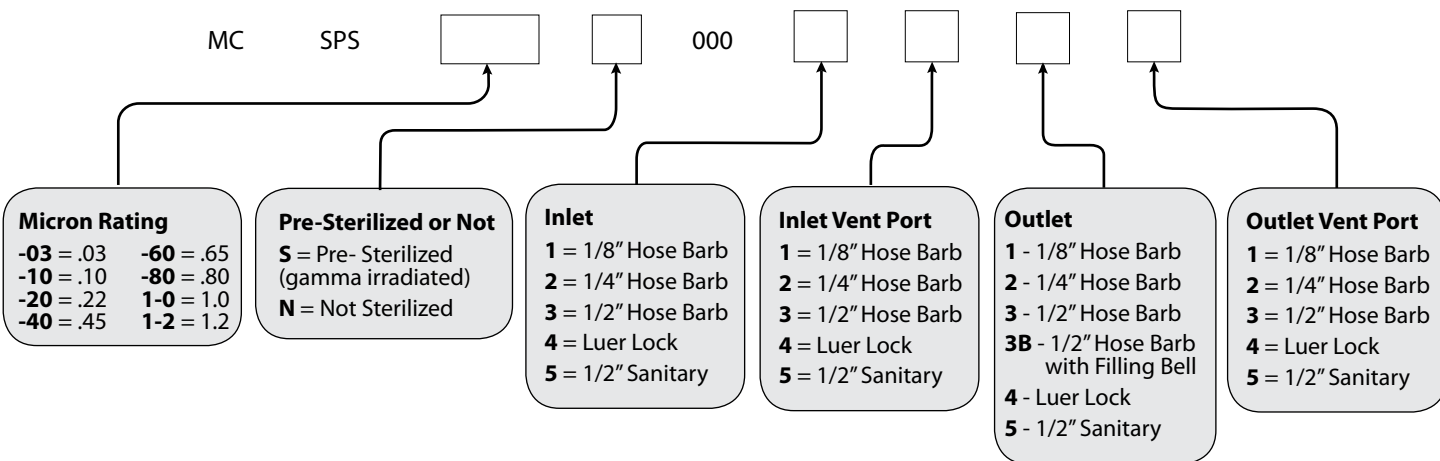

Request a **QUOTE** from your area representative



### Critical Process Filtration, Inc.

One Chestnut Street • Nashua, NH 03060  
 Tel: 603.880.4420 • Fax: 603.880.4536

[criticalprocess.com](http://criticalprocess.com) • [sales@criticalprocess.com](mailto:sales@criticalprocess.com)

The information contained herein is subject to change without notice.

The Critical Process Filtration logo is a trademark of Critical Process Filtration, Inc.

Viton is a trademark of DuPont Performance Elastomers L.L.C.

© 1998-2020 Critical Process Filtration, Inc. • All Rights Reserved • Data Sheet MCSPSDS1119 RevA

## Extractables

Pharmaceutical grade filters typically exhibit low levels of non-volatile residues. The levels of bacterial endotoxins in aqueous extracts from pharmaceutical grade filters are below current USP limits as specified for water for injection.

## USP Biosafety and FDA Compliance

The materials used to construct pharmaceutical grade SPS mini-capsule filters are non-toxic and meet the requirements for the MEM Elution Cytotoxicity Test and the requirements for Biological Reactivity Tests in the current version of the United States Pharmacopeia (USP) for Class VI - 121 °C Plastics. In addition, the materials meet the requirements listed by the FDA as appropriate for use in articles intended for repeated food contact as specified in Title 21 CFR sections 174.5, 177.1500, 177.1520, 177.1630, 177.2440, and 177.2600 as appropriate. SPS mini-capsule filters comply with Title 21 CFR sections 210.3 (b)(6) and 211.72, for non-fiber releasing filters. The levels of bacterial endotoxins in aqueous extracts from pharmaceutical grade capsule filters are below current USP limits as specified for water for injection.

## Quality Assurance and Standards

Critical Process Filtration filters are designed for use in cGMP-compliant processes. Our state of the art manufacturing facility and quality management system are certified to meet ISO 9001 standards. Each operation from assembly and test to cleaning, drying, and packaging is done in appropriately rated clean rooms. Each filter is assigned a lot code and serial number to ensure the traceability of manufacturing data and materials. A sophisticated MRP system collects and processes real time data from manufacturing centers and inspection points, allowing quick and easy analysis driving constant improvements in quality.